

PRINT your name and student ID: _____

[Extra page. If you want the work on this page to be graded, make sure you tell us on the problem's main page.]

Section 1: Straightforward questions (30 points)

Unless told otherwise, you must show work to get credit. There will be very little partial credit given in this section. Each problem is worth 10 points. There is no bonus.

3. Correlation (Don't need to show work)

Which of these plots, (a), (b), (c), or (d) depicts the circular cross correlation of the signal $\vec{s}_1 = \begin{bmatrix} 1 \\ 2 \\ 1 \\ 1 \end{bmatrix}$ with

signal $\vec{s}_2 = \begin{bmatrix} 1 \\ 2 \\ 0 \\ 4 \end{bmatrix}$?

(i.e. which plot consists of the inner products of circular shifts of \vec{s}_1 with \vec{s}_2 ?)

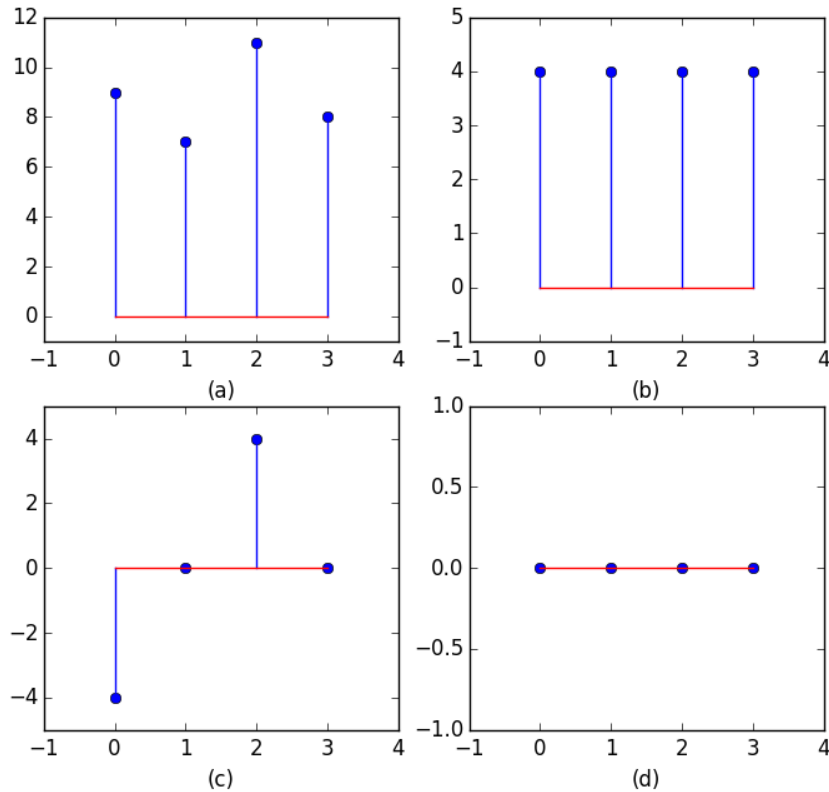

PRINT your name and student ID: _____

4. Cascading Amplifiers

(a) Use the golden rules to solve for V_{out} . (Show work)

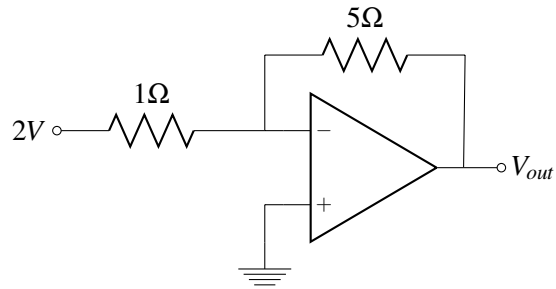

(b) Use the golden rules to solve for V_{sum} . (Show work)

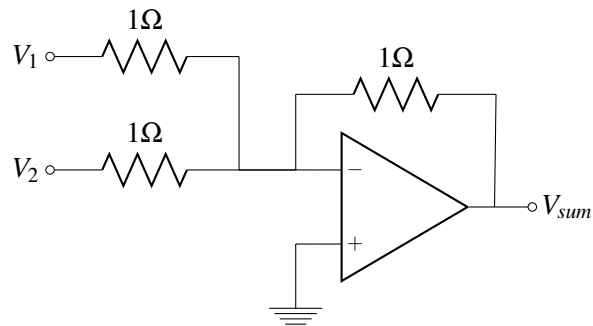

PRINT your name and student ID: _____

(c) Solve for V_{combo} . Show work. (HINT: reuse what you did in earlier parts to the extent possible.)

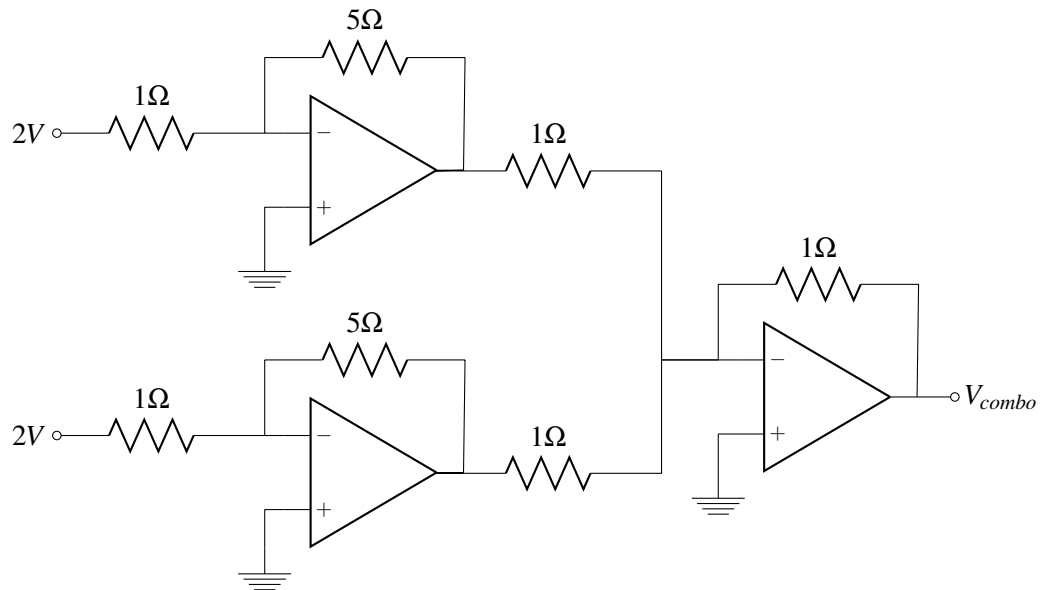

PRINT your name and student ID: _____

5. Just solve it

Solve for the voltage V_x . Where $G = \frac{1}{2}$ in units of S which are $\frac{A}{V}$.

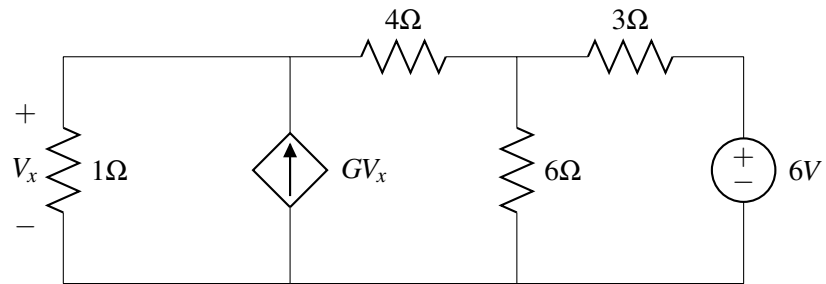

PRINT your name and student ID: _____

[Extra page. If you want the work on this page to be graded, make sure you tell us on the problem's main page.]

PRINT your name and student ID: _____

Section 2: Free-form Problems (78 + 15 points)

6. “CapRank” (28+5 pts)

Consider the circuit below, with two switches. Initially in phase 0, both switches are open, and the three capacitors start with charges $Q_1[0]$, $Q_2[0]$ and $Q_3[0]$ respectively.

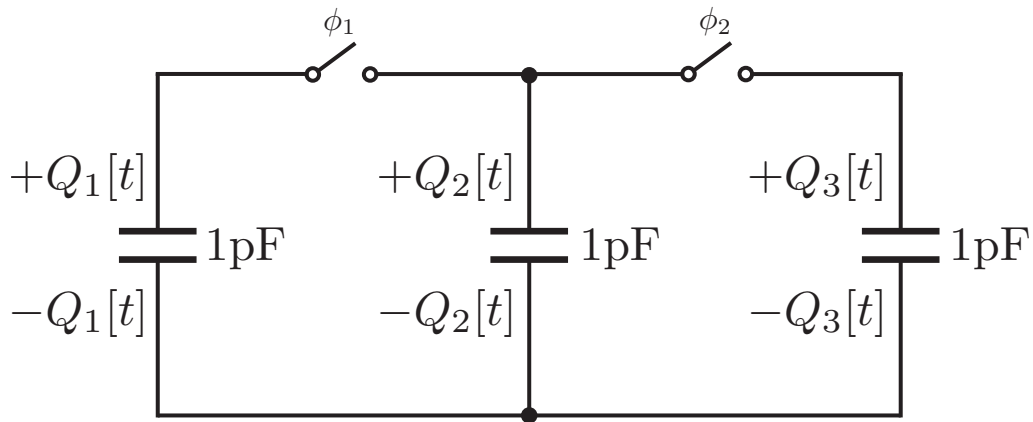

Throughout this problem, assume that when capacitors are connected, charge-sharing between them happens instantaneously.

- (a) (4 pts) At the first time step we are in phase 1: switch ϕ_2 is left open, and switch ϕ_1 is closed. **Compute the charges on all three capacitors after the first time step: $Q_1[1]$, $Q_2[1]$ and $Q_3[1]$.** (Your answer should be in terms of the initial charges $Q_1[0]$, $Q_2[0]$, $Q_3[0]$).

PRINT your name and student ID: _____

- (b) (4 pts) Let the vector $\vec{Q}[i]$ denote the charges on the capacitors $Q_1[i], Q_2[i], Q_3[i]$ after timestep i . So the initial charges are

$$\vec{Q}[0] = \begin{bmatrix} Q_1[0] \\ Q_2[0] \\ Q_3[0] \end{bmatrix}$$

And the charges after one timestep (as you computed above) are:

$$\vec{Q}[1] = \begin{bmatrix} Q_1[1] \\ Q_2[1] \\ Q_3[1] \end{bmatrix}$$

Using your answer from the previous part, we can write the relationship between $\vec{Q}[1]$ and $\vec{Q}[0]$ as a linear transformation:

$$\vec{Q}[1] = A\vec{Q}[0]$$

Write the (3×3) matrix A explicitly.

- (c) (4 pts) In the second timestep we are in phase 2: the switch ϕ_1 is opened, and then the switch ϕ_2 is closed. We can express $\vec{Q}[2]$, the charges after the second time step, in terms of $\vec{Q}[1]$, as:

$$\vec{Q}[2] = B\vec{Q}[1]$$

Write the (3×3) matrix B explicitly.

PRINT your name and student ID: _____

- (d) (2 pts) We can express $\vec{Q}[2]$, the charges after the second time step, in terms of $\vec{Q}[0]$, the initial charges, as:

$$\vec{Q}[2] = C\vec{Q}[0]$$

It turns out that $C = \begin{bmatrix} 1/2 & 1/2 & 0 \\ 1/4 & 1/4 & 1/2 \\ 1/4 & 1/4 & 1/2 \end{bmatrix}$.

What is the relationship between C and A and B from the previous parts?

- (e) (2 pts) In future timesteps, the same alternating-switching occurs between phases 1 and 2. For example, in the third timestep switch ϕ_1 is closed and switch ϕ_2 is opened. And in the fourth timestep switch ϕ_1 is opened and switch ϕ_2 is closed. And so on.

Now compute the charges on the capacitors after an even number of timesteps in general. That is, express $\vec{Q}[2k]$, the charges after the first $2k$ timesteps, in terms of $\vec{Q}[0]$, the initial charges:

$$\vec{Q}[2k] = D\vec{Q}[0]$$

Express the matrix D as some power of the matrix C (the power will depend on k).

PRINT your name and student ID: _____

(f) (12 pts) The eigenvalues of the matrix C are $\lambda_1 = 1, \lambda_2 = \frac{1}{4}, \lambda_3 = 0$. The corresponding eigenvectors

$$\text{are } \vec{u}_1 = \begin{bmatrix} 1 \\ 1 \\ 1 \end{bmatrix}, \vec{u}_2 = \begin{bmatrix} -2 \\ 1 \\ 1 \end{bmatrix}, \text{ and } \vec{u}_3 = \begin{bmatrix} 1 \\ -1 \\ 0 \end{bmatrix}.$$

Now, suppose the actual initial charges were

$$\vec{Q}[0] = \begin{bmatrix} 1 \\ 2 \\ 3 \end{bmatrix}$$

After a very large number of timesteps, what will the charges on the capacitors settle to?

That is, what is

$$\lim_{2k \rightarrow \infty} \vec{Q}[2k]$$

(Hint: Write out $\vec{Q}[2k]$ in terms of $\vec{Q}[0]$, using your answer from previous parts. Express $\vec{Q}[0] = \alpha_1 \vec{u}_1 + \alpha_2 \vec{u}_2 + \alpha_3 \vec{u}_3$ in terms of the eigenvectors \vec{u}_i found earlier. Then notice that λ_2 and λ_3 have magnitude < 1 ...)

(Extra Hint: Do you need to actually know/calculate all the coefficients $\alpha_1, \alpha_2, \alpha_3$? Notice that \vec{u}_1 is orthogonal to \vec{u}_2, \vec{u}_3 ...)

BONUS (5 pts): Can you give a physical intuition for why this has to be the right answer?

PRINT your name and student ID: _____

[Extra page. If you want the work on this page to be graded, make sure you tell us on the problem's main page.]

PRINT your name and student ID: _____

7. Thevenin In the Wild (20pts)

In this question, we will use Least-Squares to find a Thevenin equivalent circuit from (noisy) measurements. Imagine we have a black box with two terminals (a, b). This black box is a sensor whose input-output behavior varies with the magnetic field that it sees. (These are called Hall Effect sensors.)

Because this is a midterm and time is limited, we are only going to concentrate on the fact that externally, it can be modeled as a Thevenin equivalent circuit:

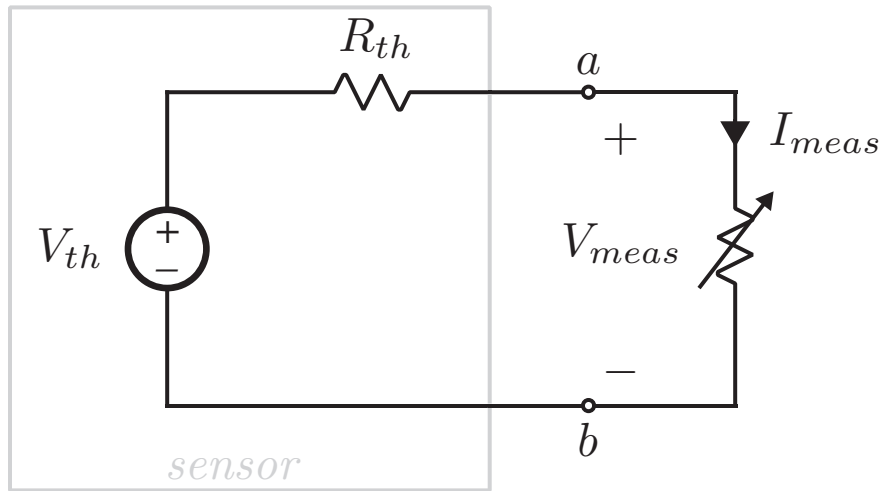

for some values of V_{th}, R_{th} .

To determine V_{th} and R_{th} , we do experiments in which we connect various resistances across the terminals (a, b), and measure the voltage differences $V_{meas} = V_a - V_b$ across the terminals as well as the currents I_{meas} .

(a) (4 pts) As a warm up, suppose we measure two pairs of voltages/currents:

- $(i_1, v_1) = (0mA, 10mV)$.
- $(i_2, v_2) = (5mA, 0mV)$.

Notice the first measurement (i_1, v_1) corresponds to measuring the open-circuit voltage, and the second measurement (i_2, v_2) corresponds to determining the closed-circuit current. **What is the Thevenin equivalent circuit for the black-box?**

(b) (6 pts) Now suppose we instead make the following two measurements:

- $(i_1, v_1) = (1\text{mA}, 4\text{mV})$.
- $(i_2, v_2) = (2\text{mA}, 2\text{mV})$.

What is the Thevenin equivalent circuit for this black-box? (It is not the same black-box as the previous part.)

(Hint: For a Thevenin-equivalent circuit with known values of V_{th} and R_{th} , can you write the voltage v as a function of the current i ? It will be $v = ci + d$ for some $c, d \in \mathbb{R}$ depending on V_{th}, R_{th})

PRINT your name and student ID: _____

(c) (10 pts)

Now, suppose we collect 4 pairs of measurements (i, v) as we try to hold the external magnetic field constant:

- $(3mA, 0.5mV)$
- $(2mA, 4mV)$
- $(1mA, 7.5mV)$
- $(0mA, 13mV)$

Set up a linear least-squares problem of the form

$$\min_{\vec{x}} \|A\vec{x} - \vec{b}\|^2$$

to determine a reasonable Thevenin equivalent circuit from the 4 measurements. What is the matrix A ? What is the vector \vec{b} ? What do the components of \vec{x} represent?

PRINT your name and student ID: _____

8. Designing for a child's party (20 +10 pts)

You are at home for winter break and are helping some friends prepare for their younger brother's birthday party.

You have access to a battery of 20V and 1Ω internal resistance.

(a) Doll (10 pts)

You find a special talking doll, but it requires a supply of exactly $\frac{20}{3}$ V. On the doll's box, it indicates that the equivalent resistance of the doll is 21Ω . You also have access to any resistors that you may want. **How would you use your battery and possibly other resistors to generate the appropriate voltage for powering the doll?** Draw the entire system (as an equivalent circuit diagram) including the doll and argue why it works.

PRINT your name and student ID: _____

(b) **Dancing Dog (10 pts)**

You find more toys and parts. One is a robotic dog that will dance if it is connected to a wire carrying an audio signal with an amplitude of 100mV. You also find a microphone, but the problem is that it doesn't have an amplitude of 100mV. Instead, it can be modeled as a voltage source of 1mV and internal resistance of 50Ω .

Using a single operational amplifier with infinite gain, infinite input resistance, and zero output resistance, and as many resistors of any values that you like, please design a circuit that amplifies the microphone signal into something that will make the dog dance. (The sign of the audio voltage into the dog doesn't matter. As long as its absolute value is 100mV.) Why does this work?

PRINT your name and student ID: _____

(c) **Baking (Bonus 10 pts)**

You decide to make a little oven (from scratch) for the party so the kids can bake things. In order to do this you will need a filament to radiate heat inside the oven. A filament can be modeled as a resistor with all the power dissipated by the resistor being converted into heat.

You find a 1m-long strip of some filament material that has a resistance of $20\ \Omega$ and you want to cut a length of it to connect it directly to your 20V battery (which has internal resistance of $1\ \Omega$) to heat the play oven. (Assume that the resistance will be proportional to the length that you cut.)

i. How long should you cut the strip to maximize the amount of heat generated in the oven?

Show your work.

ii. How much heat (in units of Watts) is available in the oven? Show your work.

PRINT your name and student ID: _____

[Doodle page! Draw us something if you want or give us suggestions or complaints. You can also use this page to report anything suspicious that you might have noticed.]